

bitubo

RACE SUSPENSION



QUALITY SYSTEM CERTIFICATED
UNI EN ISO 9001:2008
50 100 9149

Codice: SC 180 WMI 01V1

REV01

Mod. ISTR. MONT. WMB

del 27/11/2020

Pag. 1 / 9



NUMERO DI MATRICOLA

DA INDICARE IN CASO DI RECLAMO

PRIMA LA TUA SICUREZZA !**ATTENZIONE !**

Gli Ammortizzatori sono un importante componente dello Scooter, e in questo manuale è descritto il metodo corretto per il montaggio di essi.

NOTA BENE: Gli ammortizzatori devono essere installati unicamente presso un'officina specializzata; in caso di dubbi sulle istruzioni qui contenute, Vi preghiamo di contattare subito un tecnico Bitubo.

ATTENZIONE !

Bitubo non potrà essere responsabile di modifiche apportate Prodotto che non sono contenute in questo manuale, e che non sono autorizzate per iscritto. Bitubo inoltre non potrà essere responsabile di una non corretta installazione del Prodotto.

Leggete attentamente questo manuale, per ottenere dagli ammortizzatori il massimo delle prestazioni e del rendimento.

NOTA BENE: la garanzia dell'Ammortizzatore cessa nel caso in cui venga montato in maniera errata, o modificato, senza l'approvazione scritta da Bitubo.

Bitubo non potrà essere responsabile di danni al prodotto o alle persone, in caso le istruzioni contenute in questo manuale non vengano seguite esattamente, o in caso il montaggio degli Ammortizzatori non venga effettuato presso una officina specializzata, e da personale qualificato.

BITUBO RACCOMANDA



Le immagini e le indicazioni riportate sono a titolo indicativo; C.d.a. Bitubo si riserva la facoltà apportare qualsiasi modifica o variazione senza alcun preavviso.

ISTRUZIONI DI MONTAGGIO

- 1) Mettere la moto sul cavalletto centrale.
- 2) Posizionare sotto la ruota posteriore uno spessore adatto a sostenere il gruppo motore.
- 3) Rimuovere gli ammortizzatori originali seguendo il Manuale di officina della Casa Costruttrice del veicolo (Libretto Uso/Manutenzione – Manuale di Officina).
- 4) Montare gli ammortizzatori Bitubo.

ATTENZIONE:

- L'ammortizzatore con vaschetta va montato a sinistra.
 - Inserire gli ammortizzatori negli attacchi superiori rispettando la sequenza dei componenti visualizzata in figura 1. Serrare a fondo il dado di fissaggio superiore, con la coppia di serraggio consigliata dal Costruttore.
 - Inserire le viti degli attacchi inferiori facendo attenzione di posizionare la coppia di distanziali come mostrato in figura 1 e 2. Avvitare a mano i dadi di fissaggio delle viti di attacco.
 - Fissare la vaschetta la braccio oscillante come mostrato in figura 3.
- 5) Far scendere lo scooter dal cavalletto centrale, eseguire alcuni molleggi sul posteriore, quindi avvitare a fondo i dadi di fissaggio degli attacchi inferiori, alla coppia di serraggio indicata nel Manuale di officina della Casa Costruttrice del veicolo (Libretto Uso/Manutenzione – Manuale di Officina).
 - 6) Rimontare i tutti i componenti originali rimossi, seguendo le indicazioni fornite dalla Casa Costruttrice del veicolo (Libretto Uso/Manutenzione – Manuale di Officina).

N.B. Per le regolazioni dell'ammortizzatore, consultare il manuale della sospensione.

Montaggio attacco superiore

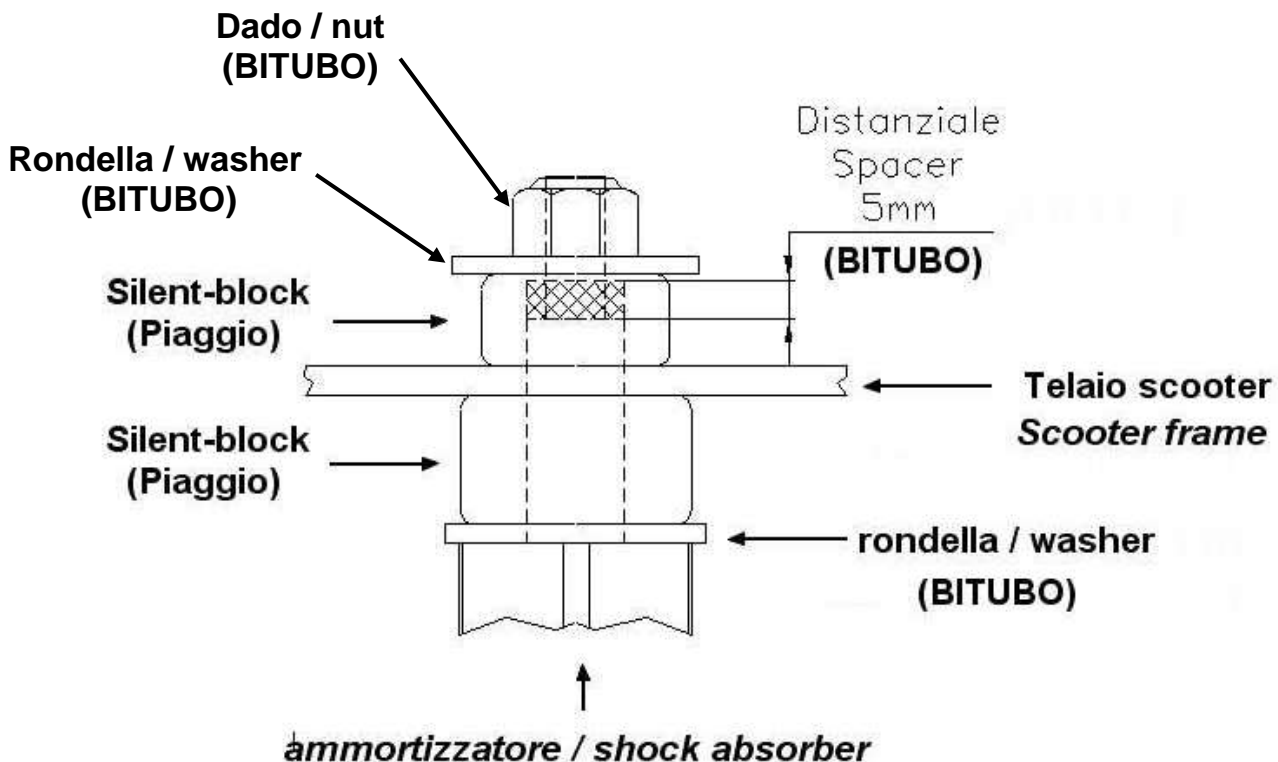

FIG. 1

Schema di montaggio attacchi inferiori
Lower attachment installation scheme

Sinistro / Left

Destro / Right

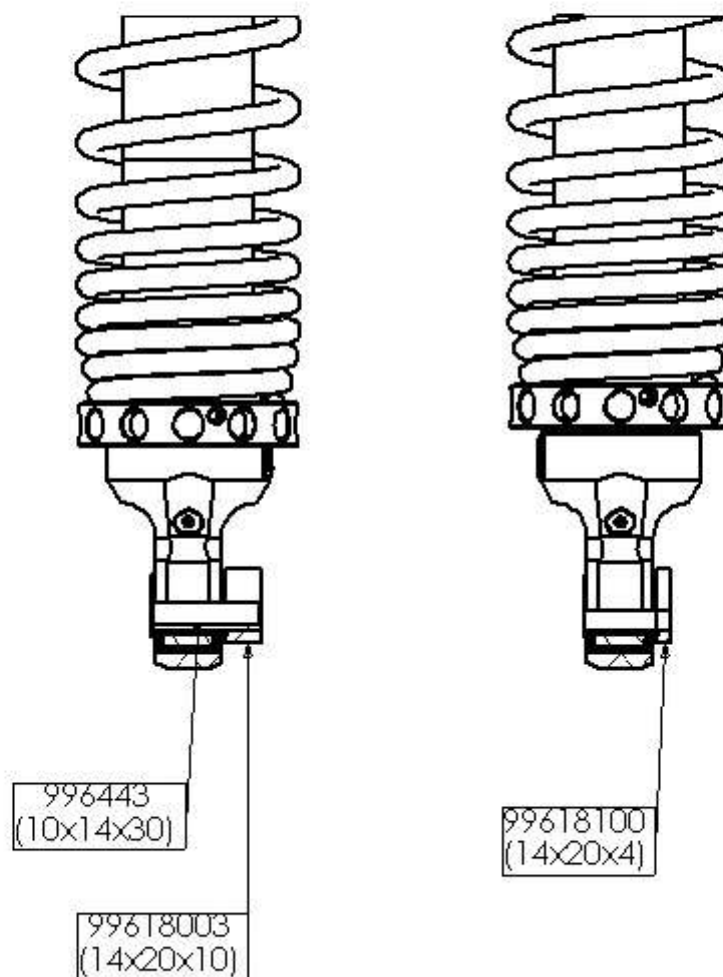

FIG. 2

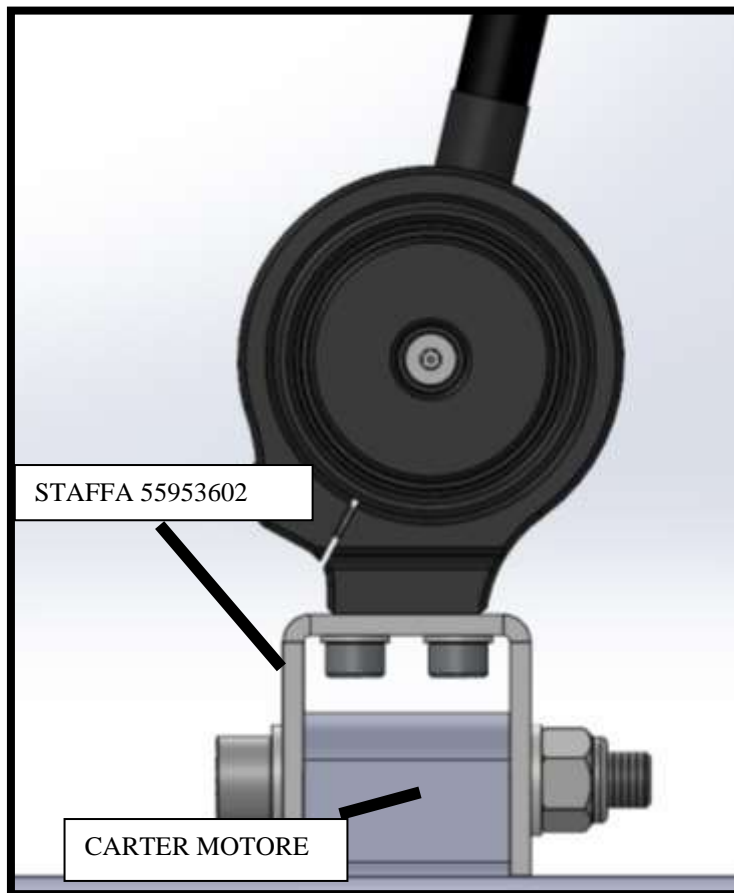

FIG. 3

VESPA WMI SCOOTER MOUNTING INSTRUCTION

bitubo
RACE SUSPENSION



Code: SC 180 WMI 01V1

REV01

Mod. ISTR. MONT. WMB

del 27/11/2020

Pag. 4 / 9



SERIAL N.

(SEE PAGE 1)

TO BE MENTIONED IN CASE OF CLAIM

YOUR SAFETY FIRST!

WARNING !



The rear Shocks are important components of the scooter and this manual describes the correct way to assemble it.

NOTE: The Rear Shocks must be installed exclusively in a specialised workshop; if you have any doubts regarding these instructions, please contact a Bitubo engineer straight away.

WARNING !



Bitubo cannot be held responsible for any modifications to the Rear Shocks not described in this handbook or not authorised in writing. Moreover Bitubo cannot be held responsible for the incorrect installation of shock absorber.

Read this handbook carefully so that you can get the best performance and efficiency out of the Shock absorbers.

NOTE: The warranty for the Shock absorbers will be invalidated by incorrect installation or modifications carried out without Bitubo's written authorisation.

Bitubo cannot be held responsible for any damages to the product or injuries to people if the instructions of this handbook are not followed to the letter or if the shock absorbers is not fitted in a specialised workshop or by qualified personnel.

BITUBO RECOMMENDS



Pictures and notes reported are purely as an indications; C.d.a. Bitubo reserves the faculty to make any modification or changes.

MOUNTING INSTRUCTIONS

- 1) Place the scooter on the central stand.
- 2) Apply a support under the rear wheel to uphold the engine-trasmission group.
- 3) Remove the original shock absorbers following the instruction following Workshop Manual of the Manufacturer of the vehicle (Use / Maintenance Booklet - Workshop Manual).
- 4) Install the Bitubo shock absorbers.

WARNING:

- The shock absorber with the gas tank goes on the left.
 - Insert the upper attachment follow the scheme in figure 1. Apply the top nut, and screw it at the torque force indicated by the vehicle Manufacturer.
 - Insert the two screw of the lower attachments with the spacers as shown in figure 1 and 2. Apply the nuts, and screw they by hand.
 - Secure the gas tank to the swinging arm as shown in figure 3.
- 5) Remove the support under the rear wheel, put down the vehicle, and tighten the bolts of the shock absorber with the torque forces recommended by the Manufacturer of the vehicle (Use / Maintenance Booklet - Workshop Manual).
 - 6) Reassemble all the removed original components, following the instructions provided by the Manufacturer of the vehicle (Use / Maintenance Booklet - Workshop Manual)

NOTE: for the setting of the shock absorber BITUBO, see the Setting Manual

Upper attachment mounting instruction

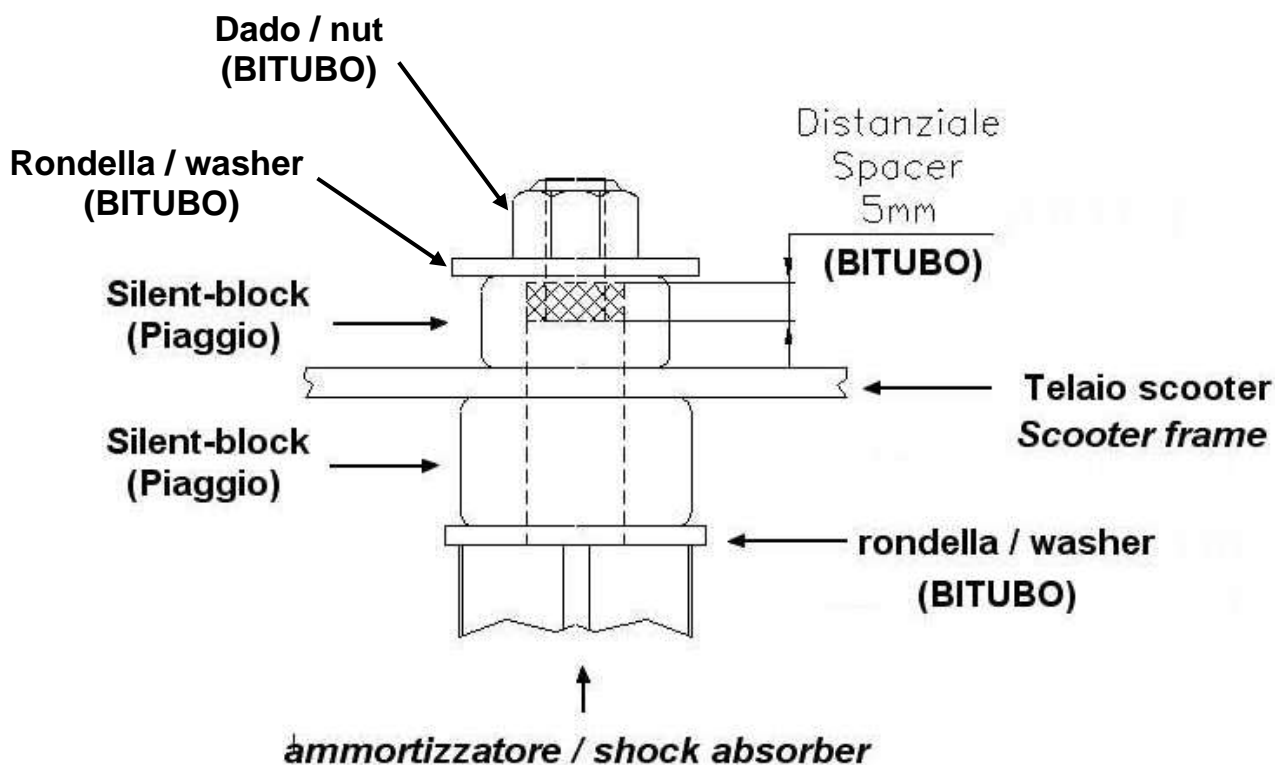

FIG. 1

Schema di montaggio attacchi inferiori
Lower attachment installation scheme

Sinistro / Left

Destro / Right

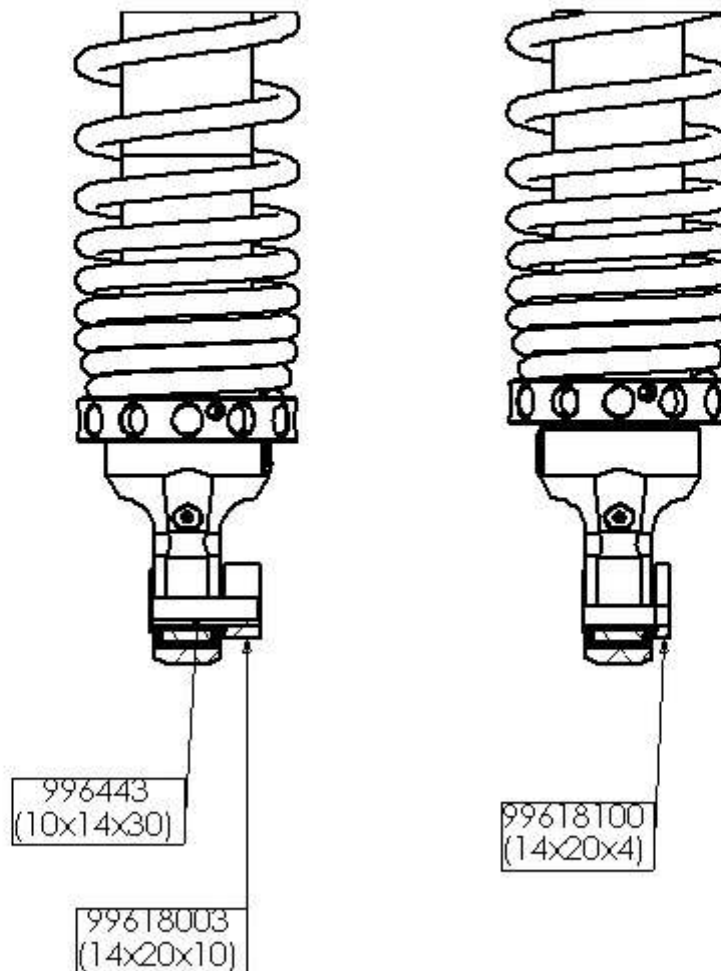

FIG. 2

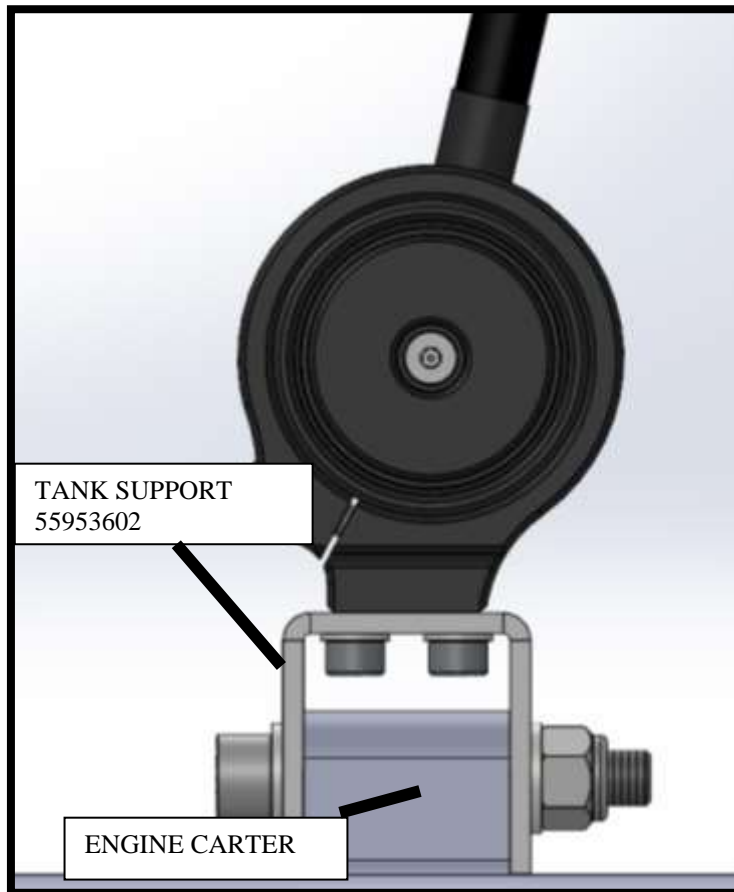

FIG. 3

bitubo
RACE SUSPENSION



Code: SC 180 WMI 01V1

REV01
del 27/11/2020

Mod. ISTR. MONT. WMB
Pag. 7 / 9



N. DE SERIE

(VOIR PAGE 1)

A INDIQUER EN CAS DE RECLAMATION

PREMIÈRE VOTRE SÉCURITÉ!



Les amortisseurs arrière sont les composants importants du scooter et ce manuel décrit la manière correcte de l'assembler

NOTE: Les amortisseurs arrière doit être installé exclusivement dans un atelier spécialisé, si vous avez des doutes sur les instructions contenues dans ce document, s'il vous plaît contacter un technicien bitubo immédiatement



Bitubo ne pourra pas être responsable pour d'éventuelles modifications aux amortisseurs arrière n'est pas décrite dans ce manuel ou non autorisée par écrit. En outre bitubo ne peut être tenu responsable de l'installation incorrecte de l'amortisseur

Lisez ce manuel du manière attentive méticuleusement afin que vous puissiez obtenir les meilleures performances et une efficacité hors du amortisseurs

NOTE: La garantie pour les amortisseurs sera invalidé par une mauvaise installation ou de modifications effectuées sans l'autorisation écrite du Bitubo.

Bitubo ne pourra pas être responsable des dommages au produit ou aux personnes, si les instructions de ce manuel ne sont pas suivies à la lettre ou si les amortisseurs ne sont pas installés dans un atelier spécialisé ou d'un personnel qualifié.



Photos et des notes rapportées sont purement à titre indicatif; Cda Bitubo se réserve la faculté d'apporter toute modifications ou changements

INSTRUCTIONS DE MONTAGE

- 1) Placer le scooter sur la béquille centrale.
- 2) Appliquer un appui sous la roue arrière.
- 3) Retirez l'amortisseur d'origine en suivant les instructions du Manuel d'atelier du constructeur du véhicule (Livret d'utilisation / d'entretien - Manuel d'atelier).
- 4) Installez l'amortisseur Bitubo.

AVERTISSEMENT:

- L'amortisseur avec réservoir doit être monté à gauche.
 - Insérer les amortisseurs dans les connexions supérieures en respectant la séquence des composants illustrés à la figure 1. Serrer l'écrou de fixation supérieur au couple de serrage recommandé par le fabricant.
 - Insérez les vis des supports inférieurs en veillant à positionner la paire d'entretoises comme indiqué aux figures 1 et 2. Visser les écrous de fixation des vis de fixation à la main.
 - Fixez le réservoir au bras pivotant comme indiqué à la figure 3.
- 5) Retirer le support à la roue arrière, posa le véhicule, et serrer les boulons de l'amortisseur avec les mesure de couple conseille par le constructeur du véhicule (Livret d'utilisation / d'entretien - Manuel d'atelier).
 - 6) Remontez tous les composants d'origine retirés en suivant les instructions fournies par le constructeur du véhicule (Livret d'utilisation / d'entretien - Manuel d'atelier).

NOTE: Pour régler l'amortisseur, consultez le manuel de la suspension

Instruction de montage de la fixation supérieure

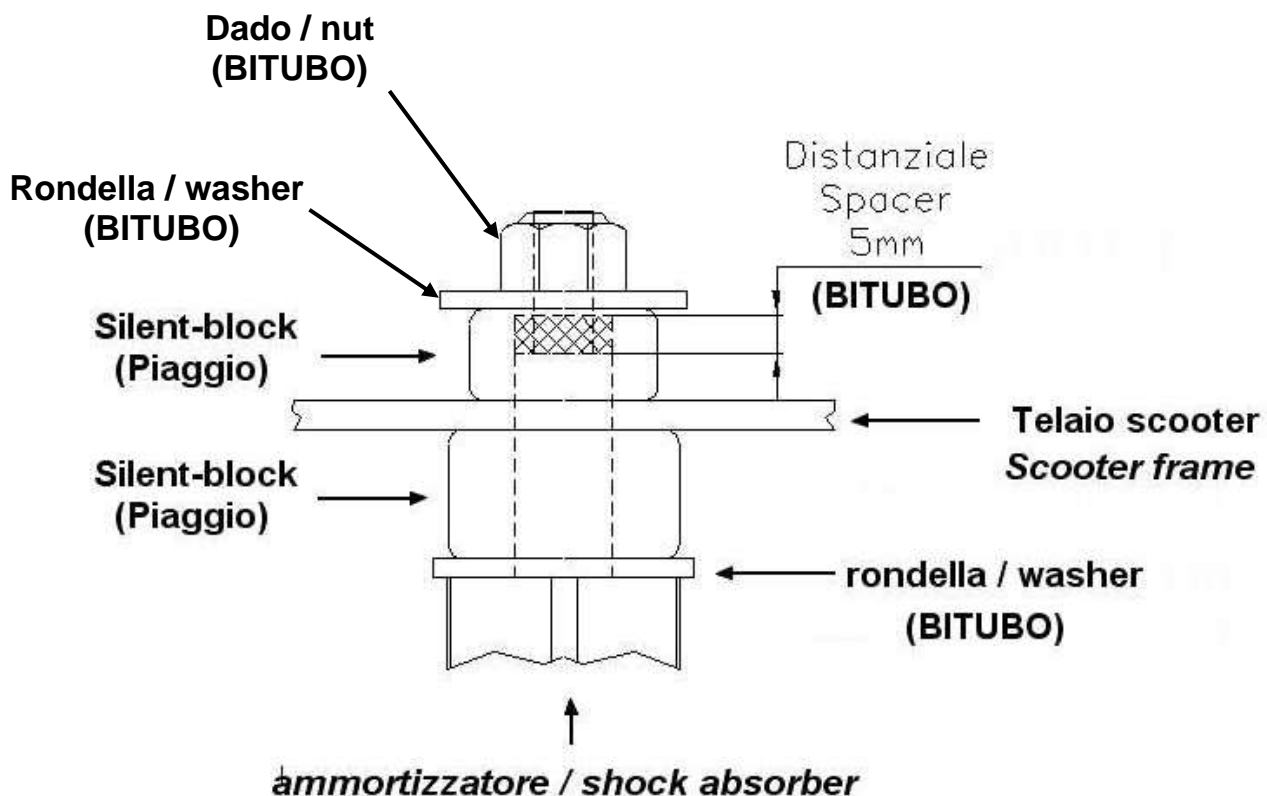

FIG. 1

Schema di montaggio attacchi inferiori
Lower attachment installation scheme

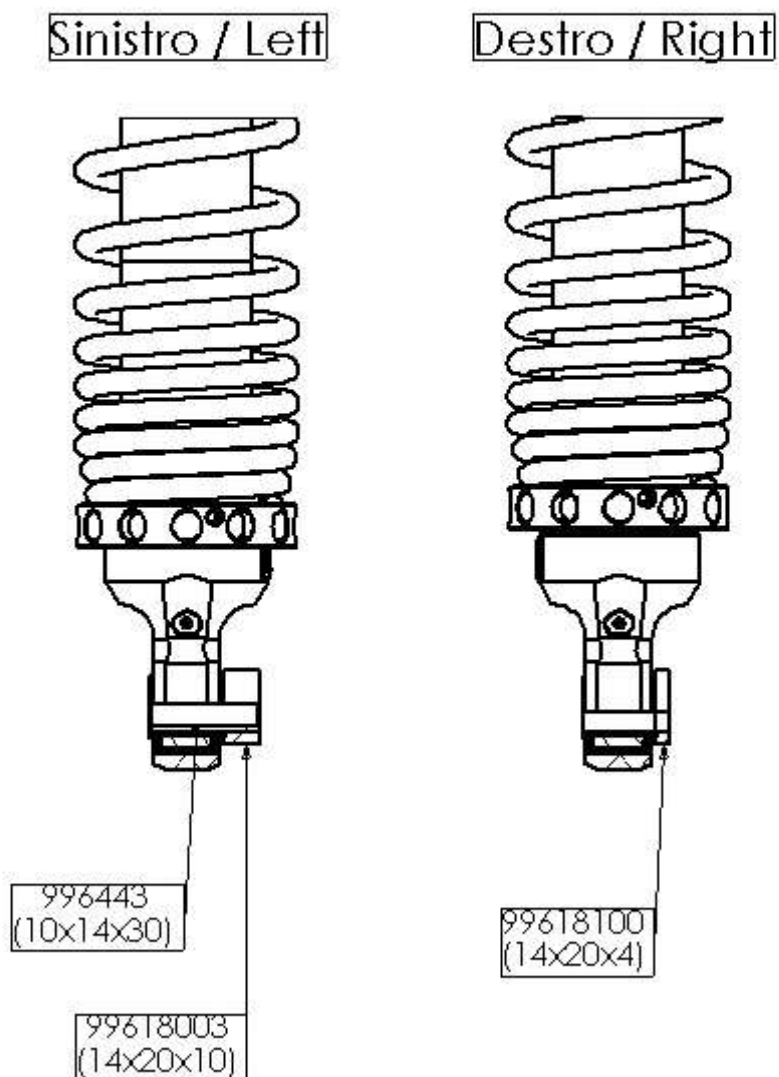

FIG. 2

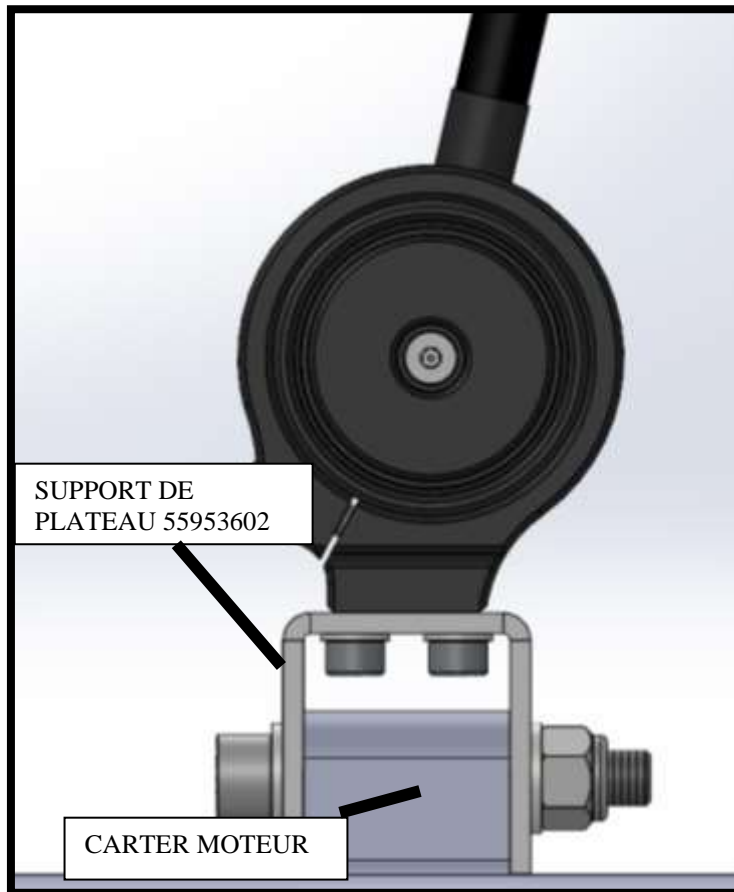

FIG. 3