

TOGLIERE IL CARTER SOTTOPEDANA, SPOSTARE I CAVI TOGLIENDO LA FASCETTA CHE LI TRATTIENE E MONTARE IL CAVALLETTA COME DA SCHEMA, APPOGGIANDO LA PIASTRA BOMBATA SUL TUBO DEL TELAIO: UNA VITE DEVE ENTRARE NEL FORO INDICATO. PRIMA DI RIMONTARE IL CARTER RITAGLIARNE UN PEZZO COME MOSTRATO IN FIGURA. RACCOMANDIAMO DI LUBRIFICARE LO SNODO

DEMONTER LE SABOT SOUSPEDANE, ELOIGNER LES CABLAGES ENLEVANT LEUR BANDE ET PLACER LA BEQUILLE SUIVANT LE DESSIN, APPUYANT LA PLAQUE BOMBE SUR LE TUYAU DU CADRE : UNE VIS DOIT ENTRER DANS LE TROU INDIQUE. AVANT DE REMONTER LE SABOT, EN DECUPER UNE PARTIE COMME MONTRE DANS LE DESSIN. NOUS RECOMMANDONS DE LUBRIFIER L'ARTICULATION.

REMOVE THE COVER BELOW THE FOOTREST, SHIFT THE CABLES REMOVING THEIR BAND AND PLACE THE STAND FOLLOWING THE DRAWING, LEANING THE ROUNDED PLATE ON THE FRAME'S TUBE: ONE SCREW HAVE TO ENTER IN THE MARKED HOLE. BEFORE REPLACING THE CARTER CUT OFF A PIECE OF IT AS SHOWN IN THE DRAWING. WE RECOMMEND TO LUBRICATE THE JOINT.

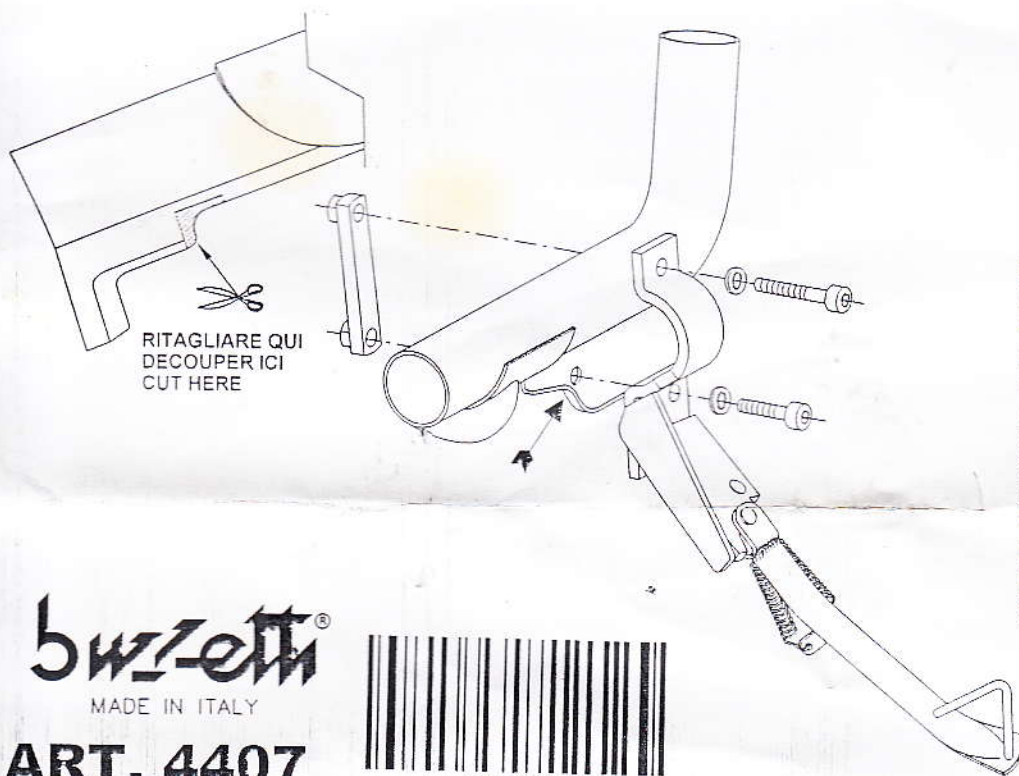

buzetti[®]
MADE IN ITALY

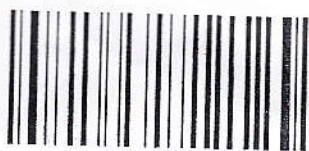

0440701001

ART. 4407

PIAGGIO CARNABY 125-200cc.

CAVALLETTO LATERALE accessorio non originale
BEQUILLE LATERALE accessoire pas original

SIDE STAND accessory not original